



CAR OIL *System S.r.l.*



Mod. **RPH** su **Fiat Ducato**
Peugeot Boxer
Citroen Jumper

SICUREZZA
VERSATILITA'
SEMPLICITA'

Sollevatore elettroidraulico semi-automatico retrattile a scomparsa sottotelaio.
Posizionato posteriormente o lateralmente al veicolo, permette la massima versatilità
relativa all'allestimento interno del veicolo.

SAFE
VERSATILE
SIMPLE

*Semi-automatic, electro-hydraulic lift that retracts and stows under the vehicle.
Rear or side installation makes it easier to furnish and equip the interior of the vehicle.*



MICO ADVANTAGE-MIN

• MOD. RPH 500

Fiat Ducato, Peugeot Boxer, Citroen Jumper

- INGOMBRO KIT:
- KIT DIMENSIONS:

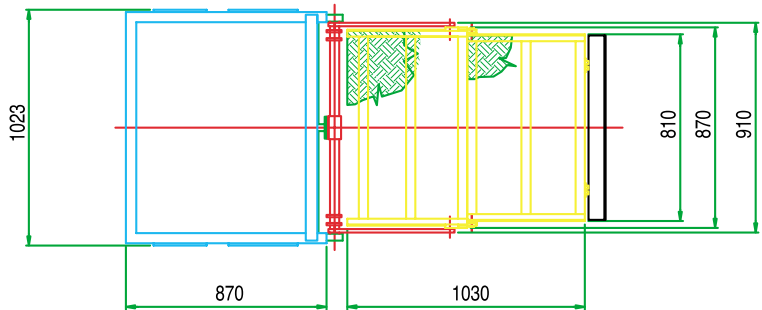
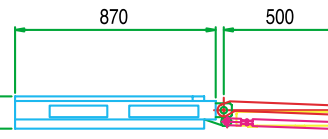
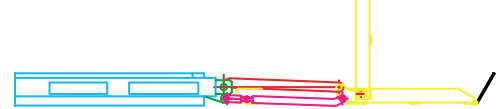
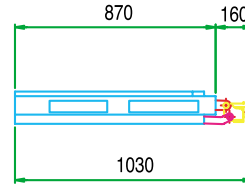
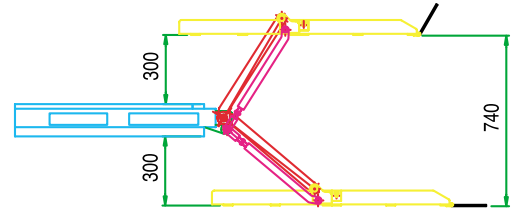

CARATTERISTICHE TECNICHE



- Capacità di carico 300 Kg.
- Alimentazione 12/24 Volts
- Comandi elettrici a pulsantiera mobile o radiocomando

TECHNICAL FEATURES



- Loading capacity 300 Kg.
- Electrical system 12/24 Volts
- Lift electric operations driven from a handheld push-button panel or remote control device

DISPOSITIVI DI SICUREZZA ED EMERGENZA

- Interruttore generale staccabatteria sull'impianto elettrico
- Pulsanti manuali di emergenza elettrica
- Dispositivi per azionamento manuale di tutti i movimenti
- Dispositivo di antischiacciamento frontale
- Ribaltina di raccordo a terra e sicurezza

SAFETY AND EMERGENCY DEVICES

- Electrical system battery cut-out switch
- Electrical emergency manual control buttons
- Manual control devices for all movements
- Front anti-crushing device
- Ground access ramp stop and safety



CAR OIL *System s.r.l.*



Mod. **EPH 200** su **FIAT Doblo'**

SICUREZZA
CONFORT
LEGGEREZZA
SEMPLICITA'

Sollevatore a funzionamento elettroidraulico, installabile lateralmente o posteriormente all'interno di veicoli trasporto disabili, ambulanze, minibus ecc...

Massima rapidità per l'installazione ed elevata semplicità di funzionamento. Pedana di carico ripiegata, per un'ottimale visibilità per il conducente e per i passeggeri del veicolo.

SAFETY
COMFORT
LIGHTNESS
SIMPLICITY

Electro-hydraulically operated lift. It can be fixed at the sides or back of transport vehicles for disabled people, ambulances, minibuses, etc... Extremely fast installation and easy to use. Foldable platform for excellent driver's and passengers' visibility.

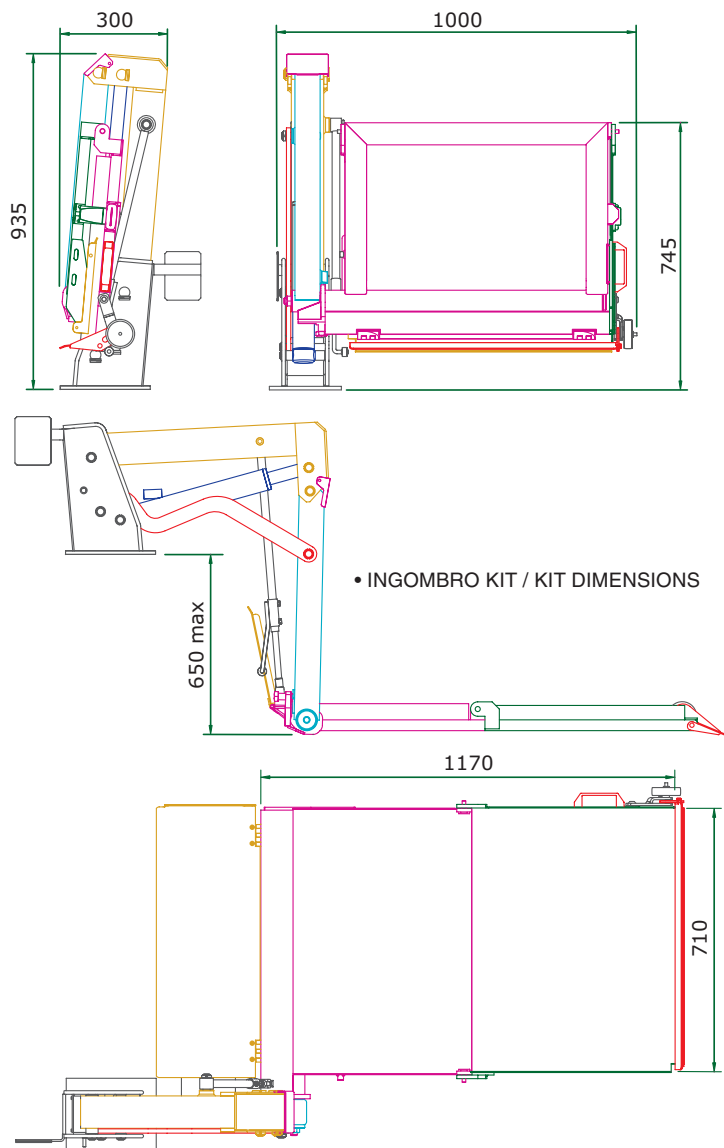

CARATTERISTICHE TECNICHE



- Capacità di carico 200 kg.
- Peso proprio 92 kg.
- Impianto elettrico 12/24 Volts
- Piattaforma in alluminio antiscivolo con ribaltina di raccordo e protezione 1170 x 710 mm
- Altezza max. elevabile 650 mm
- Comandi a pulsantiera e/o radiocomando
- Centralina elettroidraulica provvista di pompa manuale ausiliaria di emergenza
- Corrimano di protezione

TECHNICAL FEATURES



- Loading capacity 200 kg.
- Own weight 92 kg.
- Electric system 12/24 Volts
- Non-slip aluminium platform equipped with joining and safety extension 1170 x 710 mm
- Max. extending height 650 mm
- Controls with keypad and/or remote control
- Electro-hydraulic unit equipped with emergency auxiliary manual pump
- Side handrail for safety

DISPOSITIVI DI SICUREZZA

- Interruttore generale staccabatteria sull'impianto elettrico
- Pulsanti manuali ausiliari di emergenza
- Ribaltina su pedana per raccordo al piano di carico e per protezione antiscivolo
- Ribaltina per raccordo a terra facente anche funzione di fermo carrozzella in fase di salita/descesa della pedana
- Valvola di discesa con sicurezza manuale per effettuare la discesa di emergenza della pedana in caso di guasto elettrico
- Pompa manuale ausiliaria per effettuare la salita di emergenza della pedana in caso di avaria nell'impianto elettrico
- Bloccaggio meccanico in posizione di pedana chiusa a riposo

SAFETY DEVICES

- Battery cut-out master switch on electric system
- Auxiliary emergency push-buttons
- Platform extension to join up with the loading platform and to protect from shearing
- Extension to join up with the ground and also act as a wheelchair lock when the platform is moving up/down
- Descent valve with manual safety for the platform to go down in an emergency in the event of electric failure
- Emergency auxiliary manual pump to raise the platform in the event of failure in the electric system
- Mechanical lock with the standstill platform in the closed position



CAR OIL *System s.r.l.*



Mod. **RPH** su **Mercedes-Benz Sprinter**
Volkswagen LT

SICUREZZA
VERSATILITA'
SEMPLICITA'

Sollevatore elettroidraulico semi-automatico retrattile a scomparsa sottotelaio.
Posizionato posteriormente al veicolo, permette la massima versatilità relativa all'allestimento interno del veicolo.

SAFE
VERSATILE
SIMPLE

*Semi-automatic, electro-hydraulic lift that retracts and stows under the vehicle.
Rear installation makes it easier to furnish and equip the interior of the vehicle.*

RPH



MGO ADVANTAGE-MIN



• MOD. RPH 570

Mercedes-Benz Sprinter, Volkswagen LT

- INGOMBRO KIT:
- KIT DIMENSIONS:

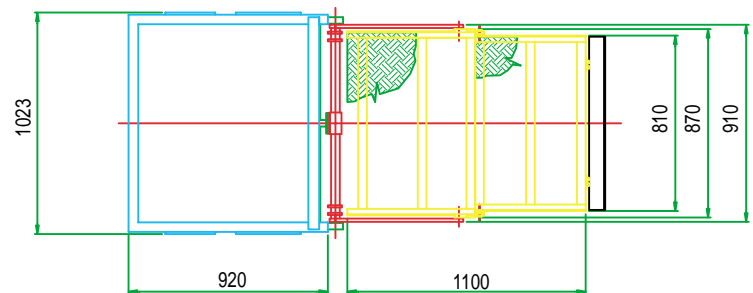
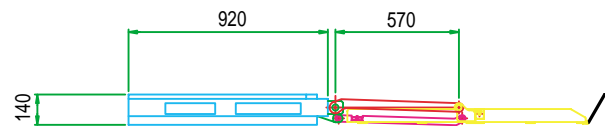
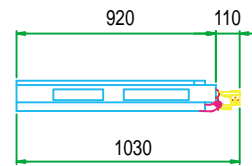
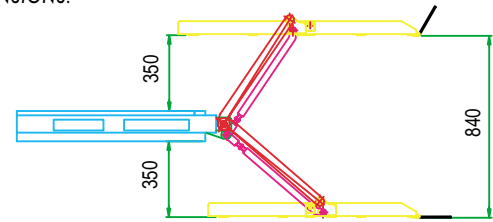

CARATTERISTICHE TECNICHE



- Capacità di carico 300 Kg.
- Alimentazione 12/24 Volts
- Comandi elettrici a pulsantiera mobile o radiocomando

TECHNICAL FEATURES



- Loading capacity 300 Kg.
- Electrical system 12/24 Volts
- Lift electric operations driven from a handheld push-button panel or remote control device

DISPOSITIVI DI SICUREZZA ED EMERGENZA

- Interruttore generale staccabatteria sull'impianto elettrico
- Pulsanti manuali di emergenza elettrica
- Dispositivi per azionamento manuale di tutti i movimenti
- Dispositivo di antischacciamento frontale
- Ribaltina di raccordo a terra e sicurezza

SAFETY AND EMERGENCY DEVICES

- Electrical system battery cut-out switch
- Electrical emergency manual control buttons
- Manual control devices for all movements
- Front anti-crushing device
- Ground access ramp stop and safety



CAR OIL



Mod. **RPH 300N** su *Iveco Daily*

SICUREZZA
VERSATILITA'
SEMPLICITA'

Sollevatore elettroidraulico semi-automatico retrattile a scomparsa sottotelaio. Posizionato posteriormente al veicolo, permette la massima versatilità relativa all'allestimento interno del veicolo. Cassetta di contenimento completamente chiusa con coperchio a funzionamento automatico.

SAFE
VERSATILE
SIMPLE

Semi-automatic, electro-hydraulic lift that retracts and stows under the vehicle. Rear installation makes it easier to furnish and equip the interior of the vehicle. Completely closed structure with automatic operation cover.

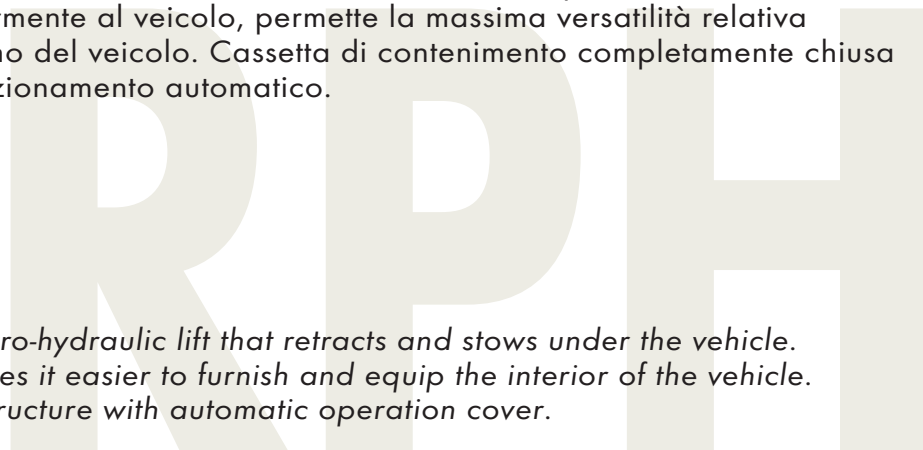



RPH 300N

Mod. RPH 300N



CARATTERISTICHE TECNICHE



- Capacità di carico 300 kg.
- Alimentazione 12/24 Volts
- Comandi elettrici a pulsantiera mobile o radiocomando

DISPOSITIVI DI SICUREZZA ED EMERGENZA

- Interruttore generale staccabatteria sull'impianto elettrico
- Pulsanti manuali di emergenza elettrica
- Dispositivi per azionamento manuale di tutti i movimenti
- Dispositivo di antischiacciamento frontale
- Ribaltina di raccordo a terra e sicurezza automatica
- Maniglie corrimano lato destro e sinistro (optionals)

• Mod. RPH 300N su Iveco Daily

INGOMBRO KIT / KIT DIMENSIONS:

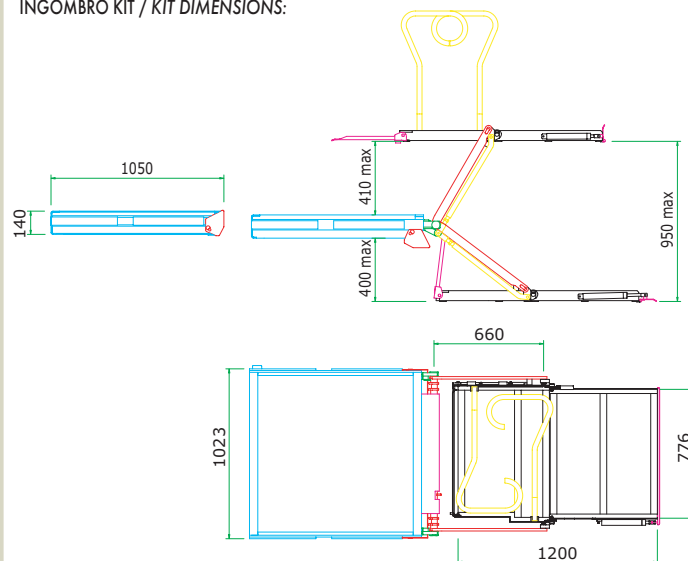

INGOMBRO KIT / KIT DIMENSIONS:

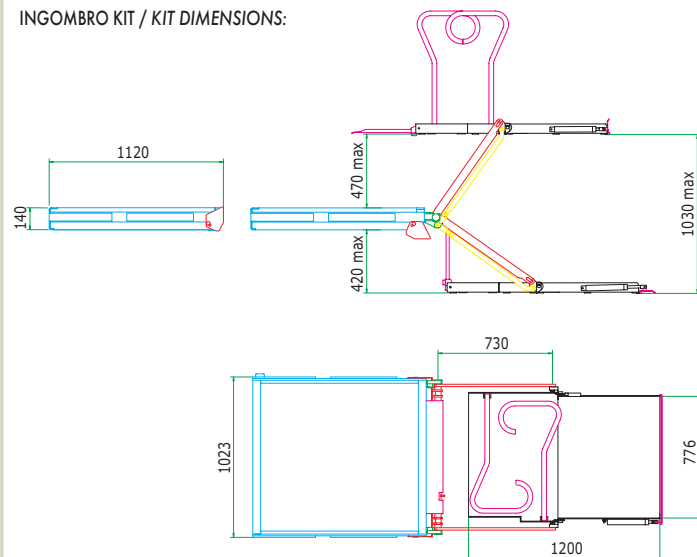

TECHNICAL FEATURES



- Loading capacity 300 kg.
- Electrical system 12/24 Volts
- Lift electric operations driven from a handheld push-button panel or remote control device

SAFETY AND EMERGENCY DEVICES

- Electrical system battery cut-out switch
- Electrical emergency manual control buttons
- Manual control devices for all movements
- Front anti-crushing device
- Automatic ground access ramp stop and safety
- Rail handles on the right and left side (optionals)